

ICS 21.060.10

English version

Drilling screws with tapping screw thread

Mechanical and functional properties

(ISO 10666 : 1999)

Vis autoperceuses avec filetage de vis à tôle – Caractéristiques mécaniques et fonctionnelles (ISO 10666 : 1999)

Bohrschrauben mit Blechschraubengewinde – Mechanische und funktionelle Eigenschaften (ISO 10666 : 1999)

This European Standard was approved by CEN on 1999-07-16.

CEN members are bound to comply with the CEN/CENELEC Internal Regulations which stipulate the conditions for giving this European Standard the status of a national standard without any alteration.

Up-to-date lists and bibliographical references concerning such national standards may be obtained on application to the Central Secretariat or to any CEN member.

The European Standards exist in three official versions (English, French, German). A version in any other language made by translation under the responsibility of a CEN member into its own language and notified to the Central Secretariat has the same status as the official versions.

CEN members are the national standards bodies of Austria, Belgium, the Czech Republic, Denmark, Finland, France, Germany, Greece, Iceland, Ireland, Italy, Luxembourg, the Netherlands, Norway, Portugal, Spain, Sweden, Switzerland, and the United Kingdom.

CEN

European Committee for Standardization
Comité Européen de Normalisation
Europäisches Komitee für Normung

Central Secretariat: rue de Stassart 36, B-1050 Brussels

Foreword

International Standard

ISO 10666 : 1999 Drilling screws with tapping screw thread – Mechanical and functional properties, which was prepared by ISO/TC 2 'Fasteners' of the International Organization for Standardization, has been adopted by Technical Committee CEN/TC 185 'Threaded and non-threaded mechanical fasteners and accessories', the Secretariat of which is held by DIN, as a European Standard.

This European Standard shall be given the status of a national standard, either by publication of an identical text or by endorsement, and conflicting national standards withdrawn, by March 2000 at the latest.

In accordance with the CEN/CENELEC Internal Regulations, the national standards organizations of the following countries are bound to implement this European Standard:

Austria, Belgium, the Czech Republic, Denmark, Finland, France, Germany, Greece, Iceland, Ireland, Italy, Luxembourg, the Netherlands, Norway, Portugal, Spain, Sweden, Switzerland, and the United Kingdom.

Endorsement notice

The text of the International Standard ISO 10666 : 1999 was approved by CEN as a European Standard without any modification.

NOTE: Normative references to international publications are listed in Annex ZA (normative).

1 Scope

This International Standard specifies the properties of heat treated screws with a tapping screw thread in accordance with ISO 1478, and which are designed with a drilling point which automatically drills the core hole for the screw during assembly. Such screws then automatically form the mating screw thread, either in a non-cutting or in a cutting operation, with the aid of the threaded portion of the screw adjoining the drilling point.

The purpose of this International Standard is to ensure that the screws are able to drill their core hole and form their mating screw thread without becoming distorted or fracturing in the process, provided that no overstressing has occurred. Consequently the following characteristics are regarded as representing the most important aspects for the assessment of the mechanical and operational characteristics of a drilling screw:

- surface hardness;
- capability of core hole drilling and forming of the mating female screw thread;
- torsional strength.

2 Normative references

The following normative documents contain provisions which, through reference in this text, constitute provisions of this International Standard. For dated references, subsequent amendments to, or revisions of, any of these publications do not apply. However, parties to agreements based on this International Standard are encouraged to investigate the possibility of applying the most recent editions of the normative documents indicated below. For undated references, the latest edition of the normative document referred to applies. Members of ISO and IEC maintain registers of currently valid International Standards.

ISO 1478:1999, *Tapping screw thread*.

ISO 4042:1999, *Fasteners — Electroplated coatings*.

ISO 6507-1:1997, *Metallic materials — Vickers hardness test — Part 1: Test method*.

ISO 15330:1999, *Fasteners — Preloading test for the detection of hydrogen embrittlement — Parallel bearing surface method*.

3 Requirements

3.1 Material

Case hardening steel or heat treatable steel shall be used as the material for drilling screws.

3.2 Metallurgical properties

3.2.1 Surface hardness

The minimum surface hardness of drilling screws after heat treatment shall be 530 HV 0,3.

3.2.2 Core hardness

The core hardness after heat treatment shall be

- 320 HV 5 to 400 HV 5 for threads \leq ST 4,2 and
- 320 HV 10 to 400 HV 10 for threads $>$ ST 4,2

including a recommended minimum tempering temperature of 330 °C.

The tempering temperature range 275 °C to 315 °C shall be avoided in order to minimize the risk of tempered martensite embrittlement.

3.2.3 Case depth

The case depth shall conform to the values given in Table 1.

Table 1 — Case depth

Thread	Case depth mm	
	min.	max.
ST 2,9 and ST 3,5	0,05	0,18
ST 4,2 to ST 5,5	0,10	0,23
ST 6,3	0,15	0,28

3.2.4 Microstructure

The microstructure of drilling screws shall not exhibit any ferrite streaks between the surface zone and the core after heat treatment.

3.2.5 Hydrogen embrittlement

For electroplated drilling screws there is a risk of failure due to hydrogen embrittlement. Therefore steps shall be taken by the manufacturer and/or the electroplater to manage the risk including test detection in accordance with ISO 15330.

In this connection ISO 4042, in which measures for hydrogen embrittlement relief are described for electroplated fasteners, shall also be consulted.

3.3 Mechanical properties

3.3.1 Core hole drilling capability

The point of the drilling screw shall be shaped in such a way that it is capable of drilling the necessary core hole for forming the mating female screw thread under the test conditions specified in 4.2.1.

3.3.2 Thread forming capability

Drilling screws shall be able to form a mating thread in the core hole drilled according to 3.3.1, without deforming their own thread when driven into a test plate in accordance with 4.2.1.1.

3.3.3 Torsional strength

Drilling screws shall have a torsional strength such that the torque necessary to cause failure, when tested in accordance with 4.2.3, shall equal or exceed the minimum torque values given in Table 4 for the applicable screw threads.

4 Testing

4.1 Testing of metallurgical properties

4.1.1 Testing of surface hardness

The surface hardness shall be tested by a Vickers procedure as specified in ISO 6507-1. The indentation shall be made on a portion of the screw as flat as possible, preferably on the head of the screw.

4.1.2 Testing of the core hardness

The core hardness shall be tested on a transverse micro-section by a with Vickers method as specified in ISO 6507-1.

4.1.3 Measuring the case depth

The case depth shall be measured microscopically on a longitudinal micro-section at the thread flank mid-point between crest and root or, in the case of drilling screws up to and including ST 4,2, in the root of the thread.

For referee purposes, a micro-hardness plot shall be made using a Vickers indenter and a 300 g load on the thread profile of a properly prepared metallographic specimen. The case depth shall be the point at which the recorded hardness is 30 HV above the actual core hardness.

4.1.4 Examination of the structure

The material microstructure shall be examined by metallography.

4.2 Testing of mechanical properties

4.2.1 Drilling and screwing-in-test

4.2.1.1 Test fixture

Figure 1 illustrates an example of a suitable test fixture.

The test plate shall be made from low carbon steel with a carbon content not exceeding 0,23 %. The hardness of the plate shall be 110 HV 30 to 165 HV 30 measured in accordance with ISO 6507-1. The thickness of the test plate shall conform to the values given in Table 2.

4.2.1.2 Test procedure

The sample screw (coated or uncoated, as received) shall be driven into the test plate until a thread of full diameter is completely through the test plate.

Axial forces and rotational speeds as specified in Table 2 shall be applied for the drilling and screwing-in-test.

4.2.2 Inspection of the drilled hole

Subject to mutual agreement, an inspection of the drilled hole may also be carried out. For this purpose, test plates in accordance with 4.2.1.1 but with thicknesses as given in Table 3 shall be used. The test plate shall be centered with a light punch mark at the spot to be drilled. After the test plate has been drilled through, the maximum size of the drilled hole shall not exceed the limits specified in Table 3.

Figure 2 illustrates a suitable testing arrangement as an addition to the test fixture illustrated in Figure 1. The inside diameter of the bush shall be approximately 0,25 mm larger than the outside diameter of the screw thread. The length of the bush shall be selected in such a way that the drilling point protrudes out of the bush.

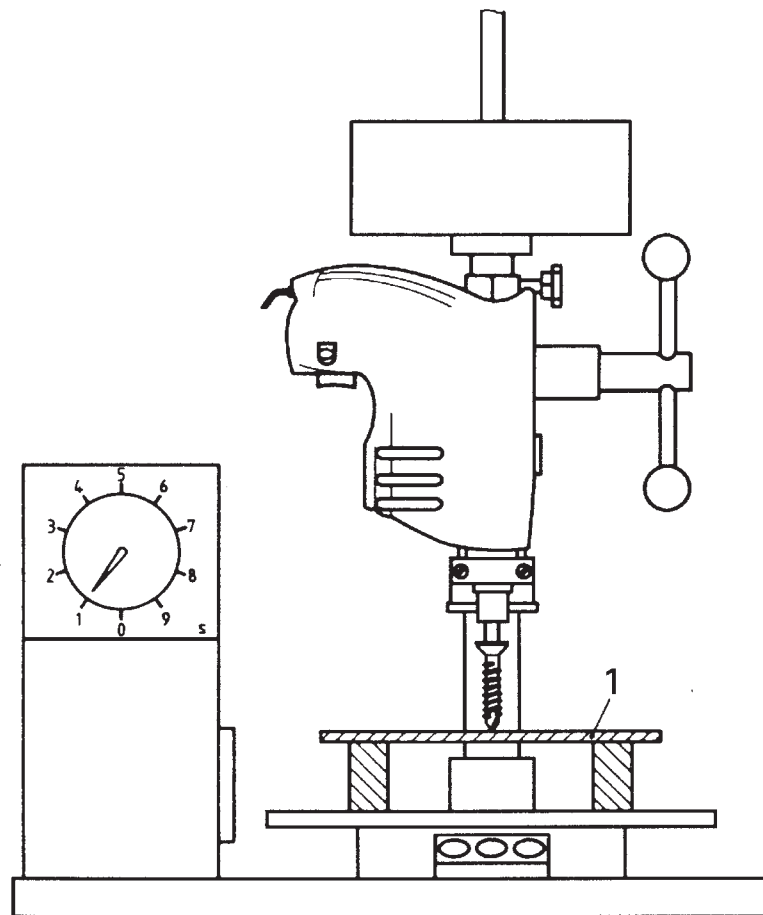

Key

1 Test plate

Figure 1 — Test fixture for the drilling and screwing-in-test

Table 2 — Test data for the drilling and screwing-in-test

Thread	Thickness of test plate ^a mm	Axial force N	Test duration max. s	Rotational speed of screw under load
				min ⁻¹
ST 2,9	0,7 + 0,7 = 1,4	150	3	1 800 to 2 500
ST 3,5	1 + 1 = 2	150	4	1 800 to 2 500
ST 4,2	1,5 + 1,5 = 3	250	5	1 800 to 2 500
ST 4,8	2 + 2 = 4	250	7	1 800 to 2 500
ST 5,5	2 + 3 = 5	350	11	1 000 to 1 800
ST 6,3	2 + 3 = 5	350	13	1 000 to 1 800

^a The thickness of the test plate may be achieved by placing two steel sheets on top of one another. These values apply to the acceptance test only.

The axial forces specified in Table 2 can also be regarded as guideline values for the application of drilling screws. If these values are substantially exceeded, the drilling points may be partially destroyed by fracture or burning up.

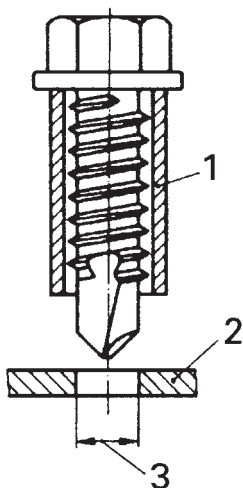

Key

- 1 bush
- 2 test plate
- 3 drilled hole

Figure 2 — Test arrangement for the drilling test

Table 3 — Test data for the drilled hole

Thread	Plate thickness mm	Hole diameter mm	
		min.	max.
ST 2,9	1	2,2	2,5
ST 3,5	1	2,7	3,0
ST 4,2	2	3,2	3,6
ST 4,8	2	3,7	4,2
ST 5,5	2	4,2	4,8
ST 6,3	2	4,8	5,4

4.2.3 Torsional test

The drilling screw to be tested shall be clamped in a split clamping device with a female screw thread, or in an equivalent testing device in such a way that the clamped portion of the drilling screw is not damaged.

Figure 3 illustrates an example of a testing appliance. After clamping, at least two pitches of the screw thread must protrude above the clamping device, and at least two pitches of the screw thread (without the drilling point) must be firmly clamped in the device or testing appliance. In the case of short drilling screws, the complete screw thread shall be firmly clamped, but the screw head shall not rest on the face of the clamping device.

By means of a suitably calibrated torque-measuring device, torque shall be applied to the screw until failure occurs. The screw shall meet the minimum torsional strengths given in Table 4.

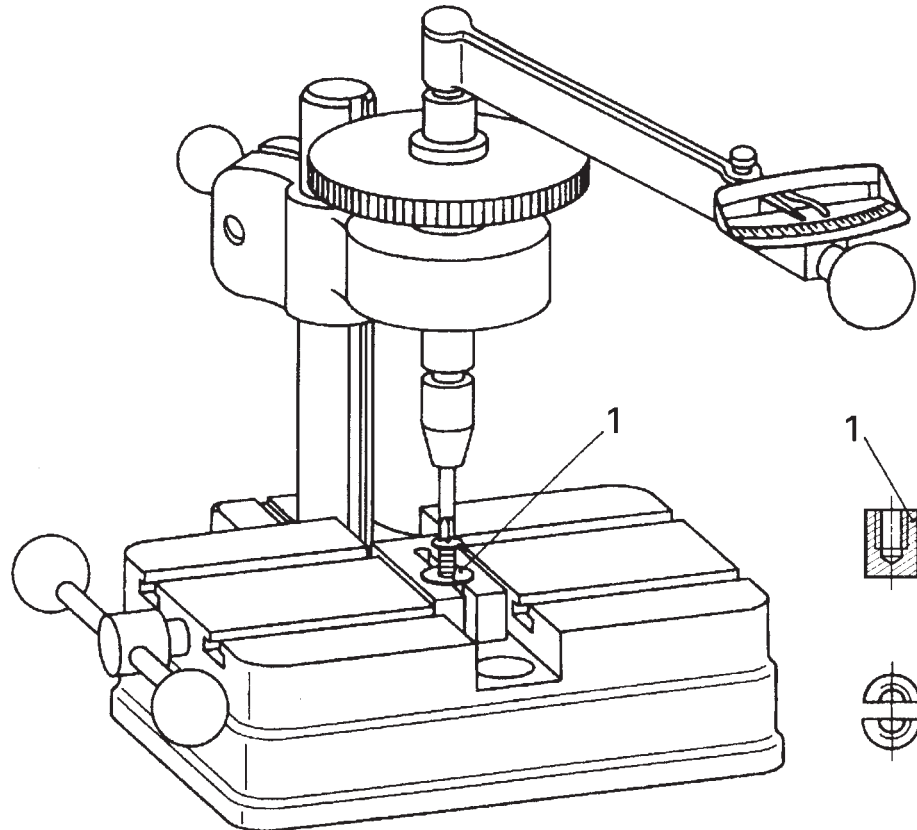

Key

1 Insert with tapped blind hole

Figure 3 — Testing appliance for torsional test

Table 4 — Minimum torsional strength

Thread	Minimum torsional strength N·m
ST 2,9	1,5
ST 3,5	2,8
ST 4,2	4,7
ST 4,8	6,9
ST 5,5	10,4
ST 6,3	16,9

5 Torque wrenches

Torque wrenches used in torsional test shall be accurate within $\pm 3\%$ of the specified torques.

Alternatively, a torque sensing power device of equivalent accuracy may be used.

For referee purposes a manually-operated torque wrench shall be used.

Annex ZA (normative)

Normative references to international publications with their relevant European publications

This European Standard incorporates by dated or undated reference, provisions from other publications. These normative references are cited at the appropriate places in the text and the publications are listed hereafter. For dated references, subsequent amendments to or revisions of any of these publications apply to this European Standard only when incorporated in it by amendment or revision. For undated references the latest edition of the publication referred to applies.

<u>Publication</u>	<u>Year</u>	<u>Title</u>	<u>EN</u>	<u>Year</u>
ISO 1478	1999	Tapping screws thread	EN ISO 1478	1999
ISO 2702	1992	Heat-treated steel tapping screws - Mechanical properties	EN ISO 2702	1994
ISO 4042	1999	Fasteners - Electroplated coatings	EN ISO 4042	1999
ISO 6507-1	1997	Metallic materials - Vickers hardness test - Part 1: Test method	EN ISO 6507-1	1997
ISO 15330	1999	Fasteners - Preloading test for the detection of hydrogen embrittlement - Parallel bearing surface method	EN ISO 15330	1999